

MOROOKA EUROPE

HIGH EFFICIENCY IN MOTION



MST110CR

Max. Payload 11T.

Full Rotating
Rubber crawler carrier

CARRIER for SOFT, SANDY and
ROUGH TERRAIN



360° rotation brings more security, less stress and fatigue to the driver



Easy Control with HST drive system

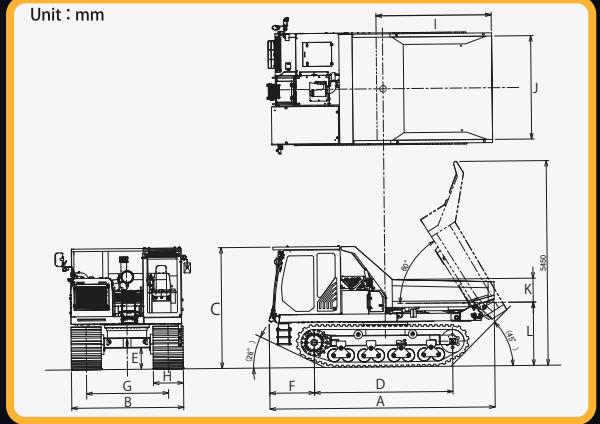

Model		MST110CR									
PERFORMANCE				DUMP BODY				TANK CAPACITY			
Maximum Payload	Kg	11,000	Overall Length	I	mm	3,050	Fuel Tank	ℓ	300		
Loading Capacity (Struck/Heaped)	m ³	4.36/6.17	Overall Width	J	mm	2,750	Hydraulic Tank	ℓ	154		
Speed1 Low	Km/h	7.6	Overall Height	K	mm	635	DEF Tank	ℓ	32		
Speed2 High	Km/h	11.8	Ground Clearance	L	mm	1,685	DRIVE SYSTEM				
Ground Pressure(empty)	kPa	35.4	ENGINE				HST				
Ground Pressure(Loaded)	kPa	59.7	Model	CAT C7.1 Tier 4 final Stage 5			GRADEABILITY				
MACHINE DIMENSION				Nominal Output/rpm			252.9(186)/2,200				
Machine Weight	Kg	16,000	Torque	N.m/min-1		1,214/1,400		Fully loaded: 27 % (15 degree) Continuous			
Overall Length	A	mm	6,000	OTHER							
Overall Width	B	mm	2,980	HYDRAULIC PUMP Main Pump 2x variable displacement axial piston pump Pilot pump 1x gear pump							
Overall Height	C	mm	3,250								
Wheelbase	D	mm	3,800								
Min. Ground Clearance	E	mm	570								
Front Overhang	F	mm	1,190	HYDRAULIC MOTOR Travel Motor 2x variable displacement axial piston motors Swing Motor 1x axial piston motor							
Crawler Distance	G	mm	2,180								
Crawler Width	H	mm	800								
Crawler Size		mm	800x 150x 66	Swing Motor 1x axial piston motor							
Cabin (ROPS/FOPS) Air Conditioning Joystick control Hardox Dump Body Auto Deceleration 360° Camera Radio											

Remarks: Specification may be changed without any notice.

MOROOKA EUROPE

Im Neugrund 14
 64521 Gross-Gerau, Germany
 Tel: +49 (0)61529778-0
 Fax: +49 (0)61529778-15
 Web: www.morookaeurope.com

Contact